

R-50 Series Rotor

INSTALLATION INSTRUCTIONS

GENERAL INFORMATION

The R-50 can be set to full circle (360°) or part circle operation (25°-350°) without the use of tools. The sprinklers factory preset to approximately 180° or half circle. The left side of the arc is fixed. This fixed position on the sprinkler can be identified by finding the double ribs on the outside of the body (see illustration 1). Because the left side of the arc is fixed, it is necessary to install the sprinkler taking into consideration its position with respect to the boundaries of the area to be watered. It is possible to turn the entire sprinkler, once installed on its fitting, to modify the position of the double ribs and thereby affect the left side of the arc. The nozzle turret can be turned manually during operation to check the arc you have set.

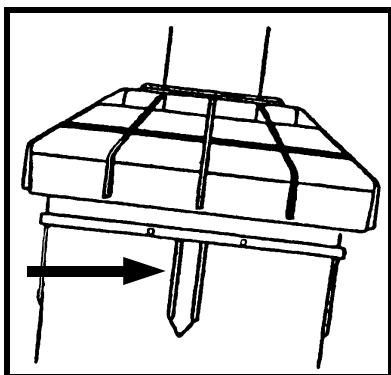

1

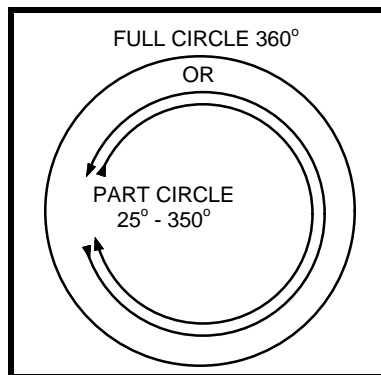

2

A unit set to full is a true, not a reversing full circle, and it operates in only one direction for superior irrigation efficiency. (See pages 6 and 7 to set the arc.)

The vandal collar located on the riser shaft must be spread and pushed down to allow adjustments to the arc. When properly pushed down, it will return to its track automatically when it pops down, if you forget to do so.

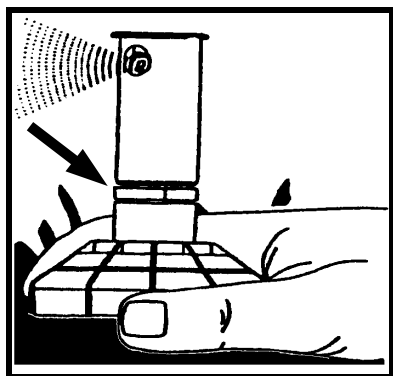

3

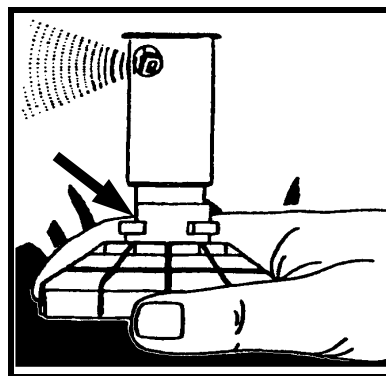

4

TIPS ON INSTALLATION

As with all sprinkler products, you must flush the system thoroughly prior to installing the R-50s.

You must use only teflon tape to make your water tight sealed connections. The use of other compounds may chemically damage and weaken the body to fitting thread connections.

The finished installation height is correct when the part of the cap as indicated is at finished grade level.

The optimum operating pressure of R-50 sprinklers is 45 PSI. After installation, if you have the means to set your system pressure, adjust it to the desired 45 PSI.

The radius adjustment screw, located on top of the nozzle turret in the colored nozzle retainer, can be used to reduce radius of throw by up to 25%. Simply use a small flat blade screwdriver to turn the screw into the water stream. The screw is captive and cannot fly out.

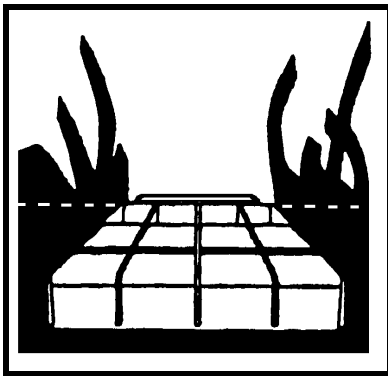

5

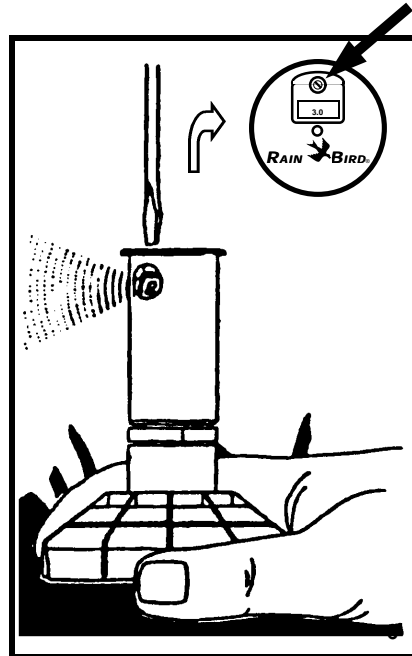

ADJUSTABLE BYPASS STANDARD MODELS

The adjustable bypass featured on the base of the standard models of the R-50 allows you to balance the flow of water through the drive mechanism to the nozzle.

Always check to ensure that the position of the bypass matches the nozzle size of the sprinkler.

Follow these steps to change the bypass setting:

- 1 Insert a flat blade screwdriver into the slot at the bottom of the sprinkler inlet.
- 2 Turn the slot so that it aligns with the desired setting based on the nozzle size in the unit. Illustration 9 shows changing from 2.0 GPM to 3.0 GPM to match the correct nozzle size (size 3 nozzle in this example).

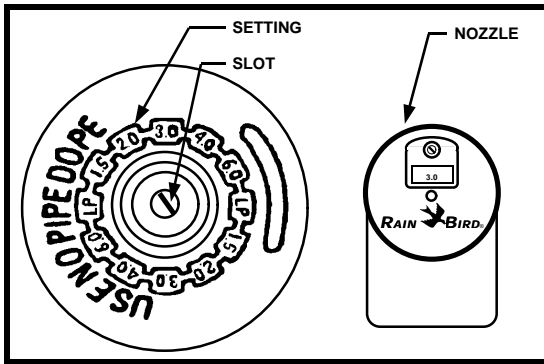

7

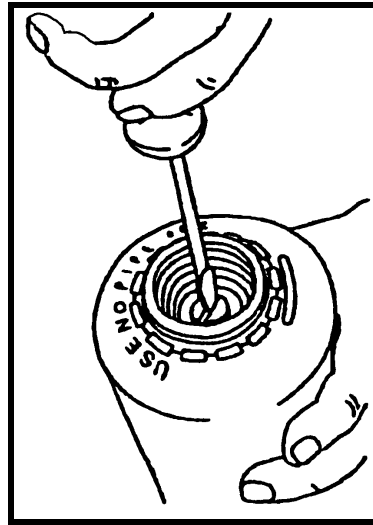

8

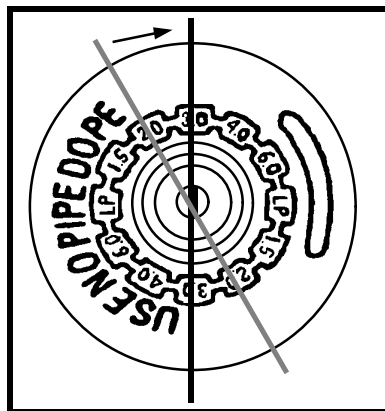

9

ADJUSTABLE BYPASS: SAM AND SHRUB MODELS

- 1 Remove the internal assembly from the case. The lower portion of the internal assembly is composed of two white parts: a screen and the drive housing. There are two ridges on the screen and the drive housing has two series of markings. These marks indicate the size of the nozzle (see key below).
- 2 Grasp the drive housing and turn the screen until the ridges on the screen align with the desired nozzle size.

KEY: 1.5 2.0 3.0 4.0 6.0

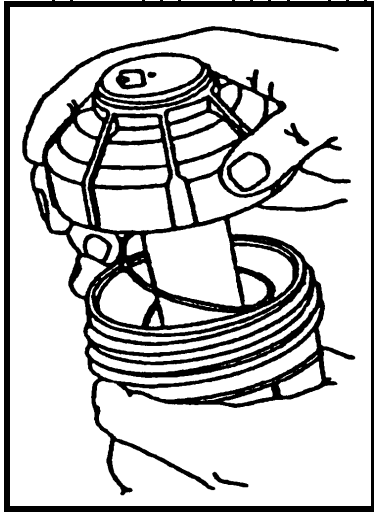

10

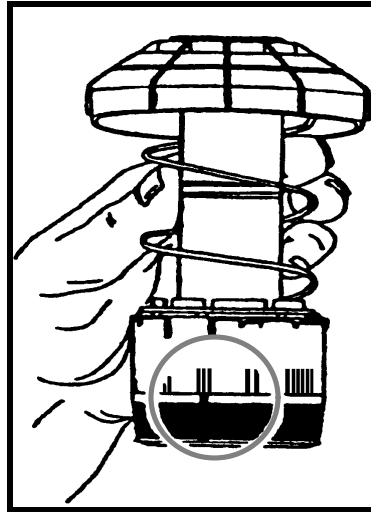

11

- 3 When returning the internal assembly to the case, ensure that you align the double ribs on the inside of the case with the larger opening on the top of the drive housing.

In some low pressure applications, you may be able to increase rotation speed by setting the bypass position one less than the nozzle size.

E.g.: For a 3.0 nozzle at 25 PSI, set the bypass to 2.0 setting if you are experiencing slow rotation.

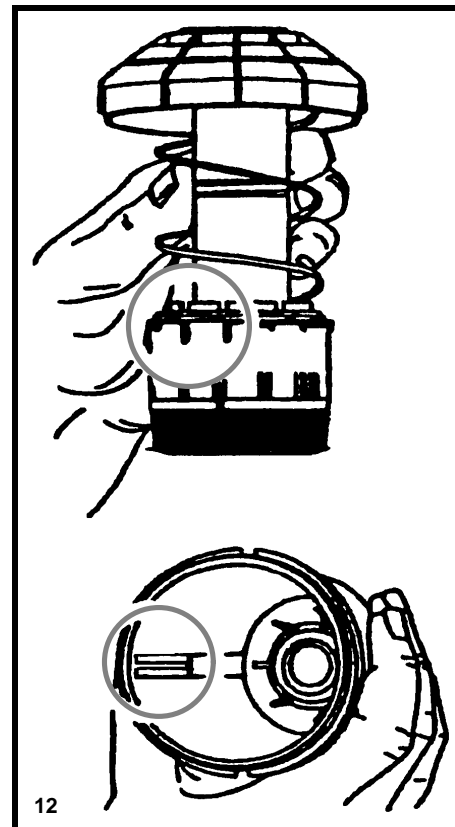

12

"QUICK" CHANGE NOZZLES

To change the nozzle follow these steps:

- 1 The first step on nozzle changing is to reset the adjustable bypass setting (as previously discussed) to the size of the nozzle you are inserting.
- 2 To lift the riser stem, place a small flathead screwdriver in the slot on either side of the top and pull up on the screwdriver as indicated in illustrations 13 and 14.
- 3 Once you have lifted the riser up, grasp at the base to hold it up.
- 4 Use a regular flathead screwdriver to pop the nozzle retainer out as pictured in illustrations 15, 16, and 17.
- 5 Insert the screwdriver into the cavity where the retainer was, position the screwdriver in the slot on the top of the nozzle, and push it out (illustration 18).
- 6 Align the new nozzle with the open cavity making sure it is properly positioned. The lip of the nozzle goes on the top.
- 7 Snap a new color coded retainer in place to secure the nozzle. Do not reuse the old retainer.

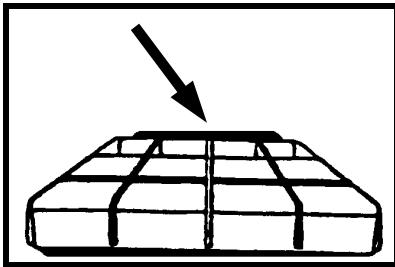

13

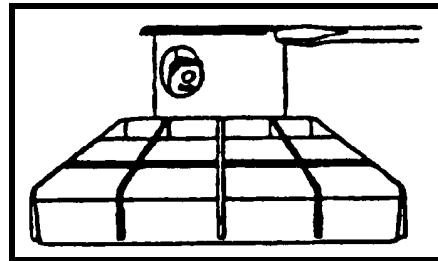

14

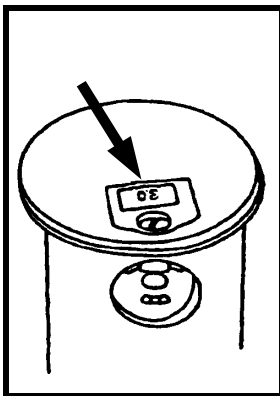

15

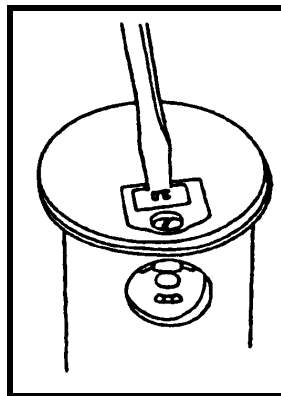

16

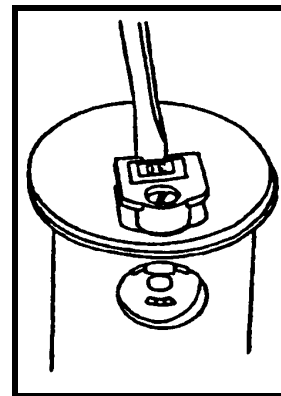

17

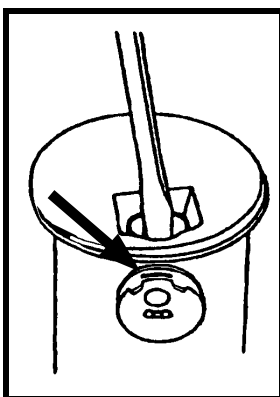

18

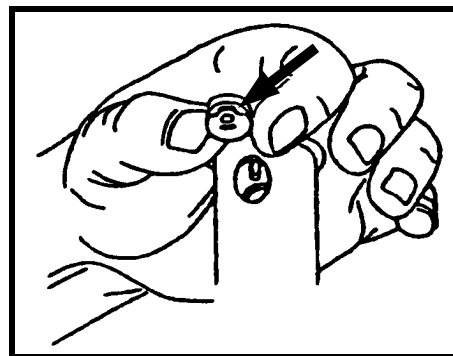

19

ARC ADJUSTMENT PART CIRCLE

To change the arc, follow these steps:

- 1 Ensure the left, fixed trip is where you want it. This position is indicated by the double ribs on the body below the cap as previously discussed on page 1, illustration 1.
- 2 While the sprinkler is up and operating, spread the vandal collar and slide it down the riser shaft as previously illustrated on page 1, illustrations 3 and 4. Do not remove the vandal collar.
- 3 **You may add arc by turning the nozzle turret in a clockwise direction.** Hold the bottom of the riser in one hand. With the other hand, push down on the nozzle turret and while still holding down, dial in the additional arc you need. Remember the preset arc is 180° and you need to add the additional amount you need, not the entire arc you want to end up with. (Illustration 21)

E.g.: The sprinkler's arc is preset to 180°, and you want an arc of 270°. While holding down and turning to the right, add 90° only. $180^\circ + 90^\circ = 270^\circ$. Remember to return the vandal collar to its original position.

- 4 **You may decrease arc by turning the nozzle turret in a counterclockwise direction.** Hold the riser with one hand. With the other hand, remove collar and push down on the nozzle turret and while still pushing down, subtract the amount of arc you wish to remove from the existing arc. Once again, the arc is preset to 180° and you need to subtract arc to get to where you wish it to be set. (Illustration 22)

E.g.: The sprinkler's arc is preset to 180° and you want an arc of 90°. While holding down and turning to the left, subtract 90° only. $180^\circ - 90^\circ = 90^\circ$. Remember to return the vandal collar to its original position.

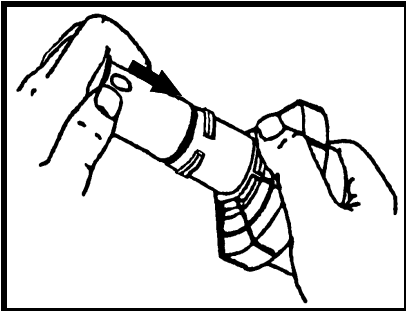

20

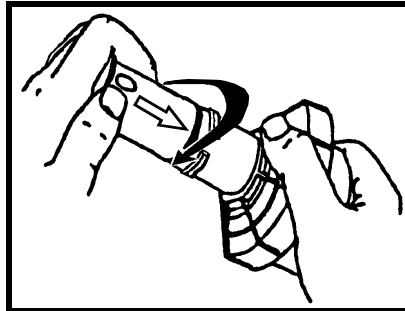

21

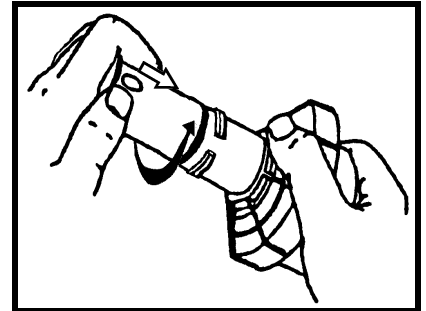

22

ARC ADJUSTMENT FULL CIRCLE

To change from the existing arc to full circle operation, follow these steps:

- ➊ Remove the internal assembly from the case by unscrewing the cap. (Illustration 23)
- ➋ Spread the vandal collar and push it down as previously discussed, and grasp base of riser. (Illustrations 3 and 4)
- ➌ Push down on the nozzle turret. Ensure that the vandal collar gap decreases to indicate you have moved into the adjustment mode. (Illustration 20)
- ➍ While holding down, turn the nozzle turret clockwise (right) until a strong resistance is felt, then go past this resistance; It should feel as though it is locked into place.
- ➎ Release the nozzle and return the vandal collar to its original position place.
- ➏ Turn the nozzle to the right (clockwise) to verify full circle set. You should feel no resistance anywhere in the 360° turn.
- ➐ To convert the arc once again to a part circle, open the vandal collar, push down on the nozzle turret and while still pushing down, turn it to the right past the trip. Once past the trip you will be defining the new part circle arc.

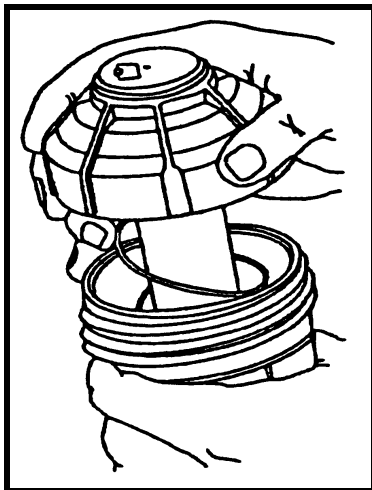

23

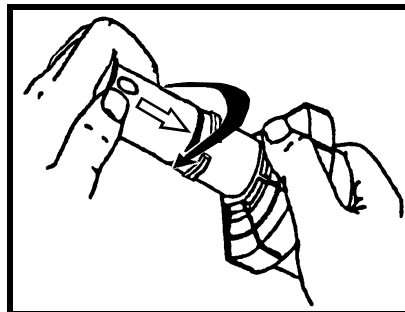

24

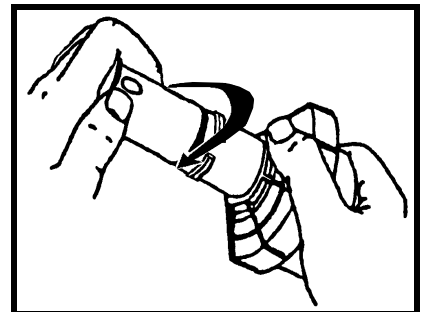

25

RAIN  BIRD®

**Rain Bird Sales, Inc.
Customer Support Center
6640 S. Bonney Ave.
Tucson, AZ 85706
1-800-RAIN-BIRD
(520) 434-6289 FAX**

PART CIRCLE ARC ADJUSTMENTS

A Spread vandal collar and push down.

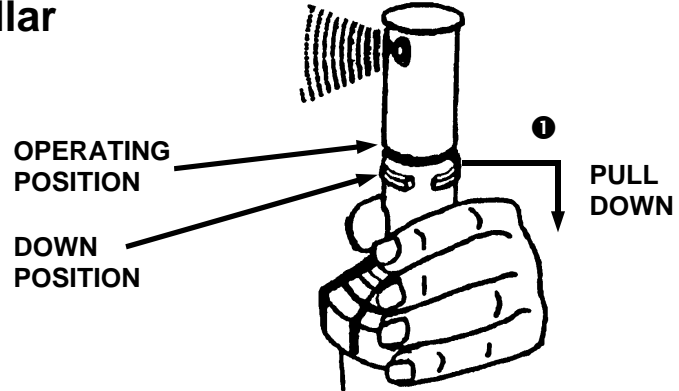

B TO INCREASE (+) ARC:

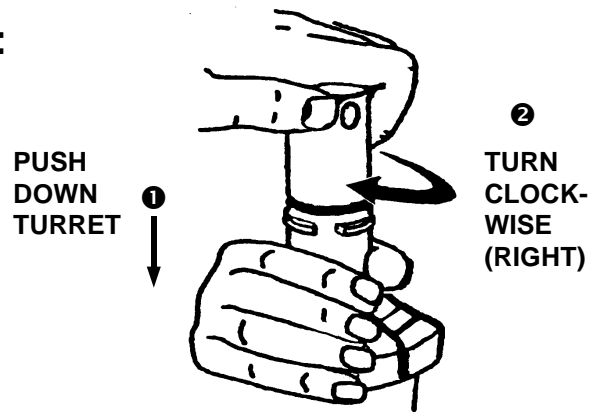

C TO DECREASE (-) ARC:

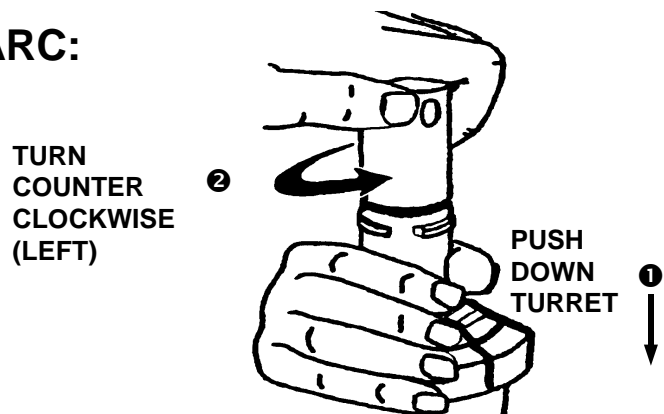

D Return vandal collar back up into slot.

R-50

RAIN  BIRD®

● FULL CIRCLE ARC ADJUSTMENTS

A

- Unscrew cap
- Remove internal assembly

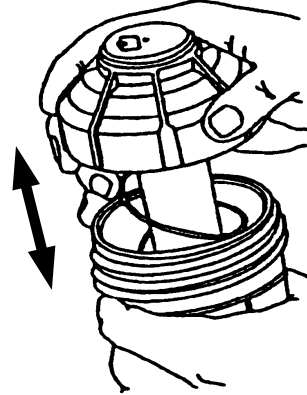

B

- Spread vandal collar and push down.

Turn counter-clockwise until resistance is felt, then turn past this resistance.

OPERATING POSITION
DOWN POSITION

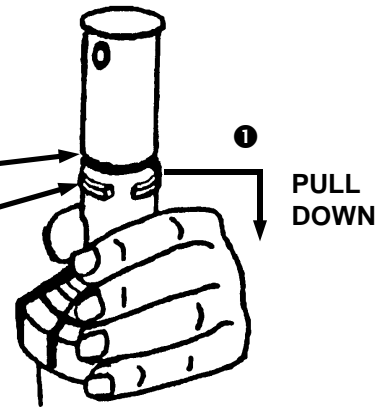

C

- Note: There should be *no* resistance anywhere in the 360° turn.

PUSH DOWN TURRET

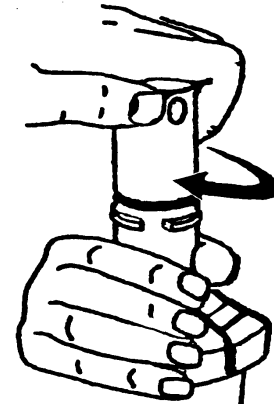

D

- Return vandal collar back up into slot and reassemble.

**PART CIRCLE ROTOR
R-50-C / R-50-S / R-50**

**Catalog No.: 407
Date: 2/95
Page: 1 of 1**

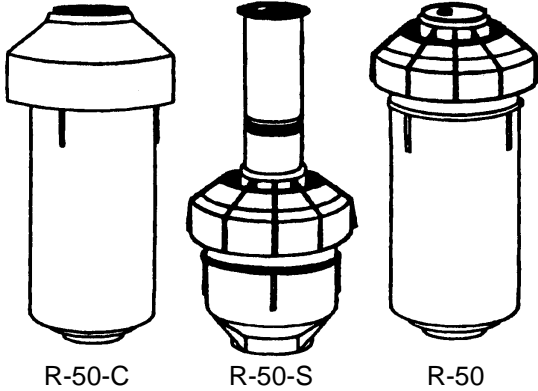
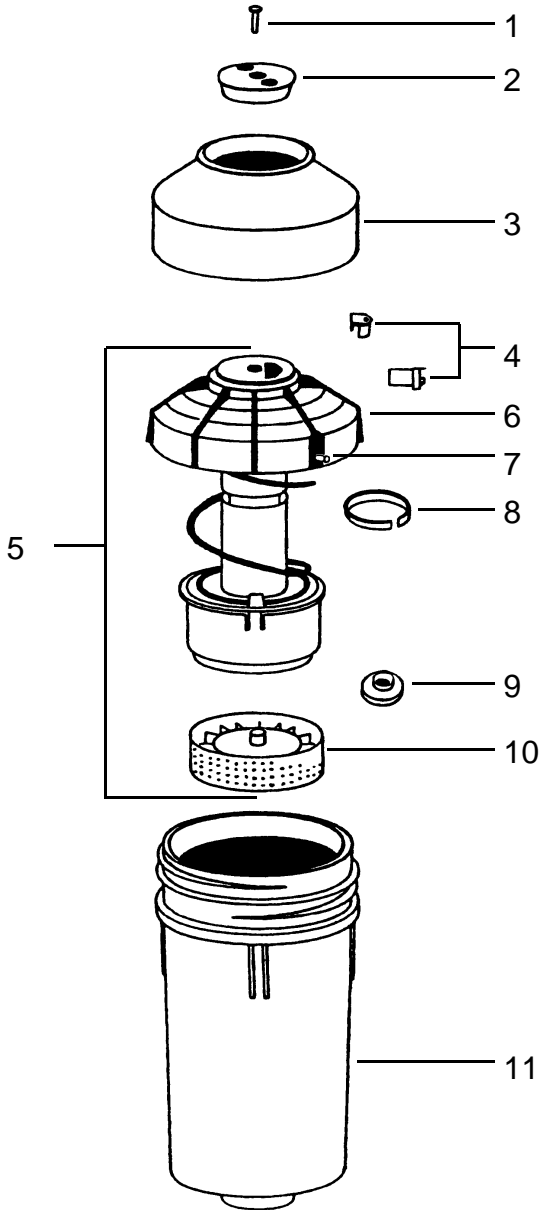

Ref.	Part Description	R-50 R-50-LA	R-50-C R-50-C-LA	R-50-S R-50-S-LA
CASES				
11	Plastic Case	113838	113838	113083
COVER ASSEMBLIES				
	Cover Assembly		A49119	
1	Turret Cover Screw Turret		(113232)	
2	Cover (Rubber) Rubber		(110758)	
3	Cover		(110757)	
NOZZLES (A) (B)				
4	Nozzle Kit	A49300	A49300	A49300
4	Rain Curtain Nozzle Kit	A49301	A49301	A49301
INTERNAL ASSEMBLY (Adjustable Bypass Version)				
5	Standard Angle	114160	(114787)	(114789)
5	Low Angle	(114788)	(114854)	(114790)
6	Cover (Plastic)	(112559)	(111120)	(111120)
7	Set Screw		(112487)	(112487)
8	Vandal Collar	109852	109852	109852
9	Flow Bushing (C)	(A)109826	(A)109826	(A)109826
10	SAM Screen (ADJ BYPASS)		114422	
10	SAM Screen (NON - ADJ BYPASS)		111948	
10	STD Screen (ADJ BYPASS)	113527	N/A	113527
10	STD Screen (NON - ADJ BYPASS)	111913	N/A	111913

(A) Specify Nozzle or Flow Bushing size when ordering.
 (B) Nozzle Kits include Nozzle Vane Assembly and Nozzle Retainer Assembly.
 (C) Flow Bushing not required on Adjustable Bypass Versions.

Note: Part numbers enclosed in brackets () are not available individually, but may be sold in assemblies or kits.